

Chateaugay Historical Society

NEWSLETTER

Volume XIII, Issue 4, 2019

Officers: Mary H. Humiston, President; Phyllis Thompson, Vice-President; Rose Mary Hiscock, Secretary; Mick Jarvis, Treasurer
Trustees: Robert Bessette, Rose Mary Hiscock, Mary Humiston, Mick Jarvis, Katelyn Legacy-Roulston, Edith Lopardo, Jo Ellen Saumier, Phyllis Thompson.
Trustees Emeriti: Mary Ellen Putnam, Peggy Roulston, James B. Humiston (1936-2015), Beverly Titus, J. Emma Perry (1935-2016), Barbara Cook, Olin Cook.
Meetings: First Monday of each month at 9:00AM in the Archival Center on the second floor of the Town Hall. **Email:** chathistsoc@gmail.com

From the desk of the President:

Would you believe this is the fourth issue of 2019, the thirteenth year of publication and the fifty-first issue we have printed?

Two of the Society's J.W. Gray oil paintings are now with Emily Phillips, Art Conservator, being cleaned and repaired. They will return in the spring, and we hope to welcome them back with an open house and reception to share the J.W. Gray Collection and its part in local history.

Another project this winter will be an exhibit on photographers and photography in Chateaugay. We have identified over 20 individuals who had a photography business in Chateaugay from the early years to the present. The exhibit will feature the progression of photographic equipment, biographies of the individuals and examples of their work. Look for this event during February and March.

Other plans for the winter months will include working with Chateaugay Central School high

school students on a World War II exhibit and contributing to a display showing the history of the local Post Office. It looks like a busy winter

The articles for this issue include the following sketches about: the very early Circuit Riders and how their records influence research of local genealogy by Phyllis Thompson, the long ago industry of shoemaking in Chateaugay by Mary Humiston, and a description of a strange invention by a local inventor written by Mick Jarvis. Also, we introduce a column that we will share from time to time describing various artifacts from our collection.

Once again, it is time to remind everyone of membership renewal. The 2020 renewal year begins January 1st. If you have not already renewed, please send in your check and form that is included in this issue. Don't know if you need to renew? Please check your **mailing label** for your expiration date (**Expires 2019**) which is found immediately **below** your name. (Please disregard any other odd dates or

numbers. They refer to the postal mailing.) Some of you may find that your membership is paid ahead for a few years due to over-payments.

In that case, you do not have to send in dues until the year listed in the expiration date below your name. Thank you to all who have already sent your renewals over the past few months.

Your continued support is very much appreciated.

Happy Holidays and have a great winter.

Mary H. Humiston



An Unexpected Find in the Methodist Parsonage

By

Phyllis Thompson, Chateaugay Historical Society

Circuit Rider's Ledger

If walls could talk, we might learn when and how the ledger of the early (1845-1860) Methodist Circuit Riders found its resting place between the walls of the Methodist Parsonage on Church Street. The Parsonage was built in 1889. The ledger was discovered when the house was being remodeled in 2017. The information in this article is from the ledger which, except for its cover being missing, is in pretty good shape for its age and storage place.

Early History

Rev. D. F. Pierce, who was pastor here in 1881-1883, wrote an early history of the Methodist Church. This information came from that history. In 1832-1833, John E. Stodard was the preacher in charge. The circuit at that time included Chateaugay, Belmont, Burk [Burke], part of Clinton and Canada that bordered on these towns. Brother Stodard used to say he often heard the wolves howl when passing through the unbroken forest.

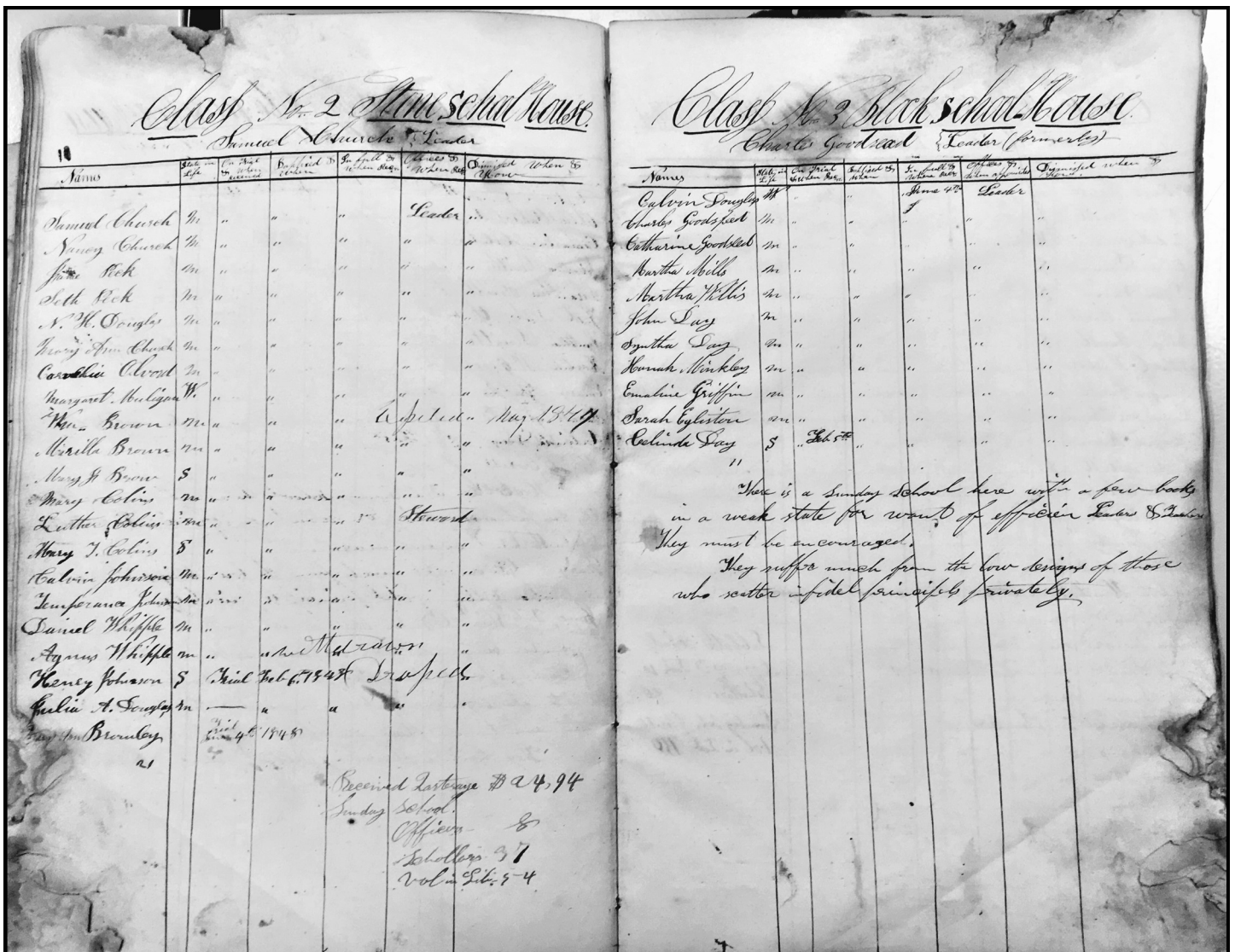

Class Lists for two meetings held in what the Reverend called the Stone Schoolhouse and the Black Schoolhouse

C. L. Duning was the preacher in charge and Benjamin F. Brown was his assistant in 1834. The following is a list of the preachers who followed Reverend Duning:

- 1835 James Erwin (Harris Kingsley - assistant)
- 1836 L. D. Gibbs
- 1837-1838 Allen Castle
- 1839 George Greenleaf
- 1840 John Wallace
- 1842-1843 Franklin Hawkins
- 1844 James N. Wilbur
- 1845-1846 Ebenezer Pease
- 1847 C. Johnson
- 1848 J. N. Brown
- 1850 Alonzo Wells
- 1851 Benjamin F. Brown.

The Methodist preachers focused on evangelizing people. These societies were divided into groups called classes. The classes met in the area school house. If this wasn't possible, they would meet in one of the member's homes.

The information in these class lists is important as they confirm the families living here in the late 1840s. The location where the classes met also helped pinpoint where the family lived. The ledger also gave the first name of the women in the class. The females were counted but not named in the Federal Census prior to 1850.

The members entered the class on a trial membership as you will see after some of the names. If a preacher was not present, the ledger contained how often the classes met, who the leader was, the amount of the collections, and if there were non-members present and how much they gave. The

A.D. 1845-56		Class No	Signer		No of times met in		Periodicals	Marriages	Deaths	Dues & Avg					
Names	Trial	Baptism	Full	Officers	Desm	In	Class	Class		1	2	3	4		
Benjamin Signer			Full	Officer & Leader			8						.46		
Jurga Signer							6	2	Remarks						
Obadiah McSwerton							2	6							
Lucretia McSwerton							1	7	Preaching once in 3 weeks						
Math. Jones							4	4	on wednes day 4 P.M. in Sum						
Sarah Pickering							1	7	and Early candle light fall						
Betsy Pickering							4	4	and winter						
Benj Pratt							2	6							
Sophiah Pratt							4	4	No in Class 18.						
Mary L. Signer							6	2	Sermons preached by me						
Henry Signer							1	7	the present conference year						
Alonzo A. Clarke				Exhorter			6	2	is 13						
Sally A. Clarke							3	5							
Emily J. White							2	6					.46		
Mary James	Trial				Without				Some friends not of our church				.46		
Saml Signer	Aug 27 1845				Letter		1	2							
Harriet Pickering			Aug 21 1846				1	2							
Mary Jane Tolpelt	May 27 1845						1								
Names	Class	No	9	Cartwright	In	Class	Not in	Class	Periodicals	Marriages	Deaths	Dues & Avg			
Sharon Cartwright			Full	Leader			1	1							
Christa J. Cartwright							2		Remarks &c						
David Hazen							1	1	This Class meets between the four			3.75			
Rebecca Hazen							2		corners and Stone School house near					.75	
Horace Hazen							2		Mr Bullards			3.75	.20		
Emerson Hazen							1	1	I have not preached to them regularly				.12		
Mariah Hazen							2		but now have Sabbath appointment				.20		
Emily Hazen							1	1	at 5 P.M. one in 3 weeks				.20		
Sary Wilks	Died June		25. 1846	of Typhoid fever			2		The No in Class is 15				.6		
Emiline Baker							1	1	No of Sermons preached by me is 6				.20		
Lewis Austin							2		The amount of Dues put in			7.50	1.18	.75	
Olafus Hazen							2								
Filinda Squires							1	1							
Sally J. Pease							2								
Borshaba Vaughn							2								

These ledger pages contain information on individuals in specific classes

ledger also noted if there was a Sunday school, a Bible class and/or a library connected with the class. The ledger also listed when someone joined a class or left it by transferring or just left permanently. There were also a few deaths and marriages noted.

I have mainly included the names from the early years of the ledger as these are the ones that gave the female names not necessarily found elsewhere, as women were not listed by name in the U. S. Census records prior to 1850. On the later pages, in many cases, repeat names found. As people moved about in the area their names may be in one class and later found in a different one.

An Example of Information That Can Gleaned from a Ledger Like This One

I found that the names, in many cases, matched with the burials in the cemeteries of the neighborhoods where they had attended class. In Class No. 8, there is a Mary L. Signor listed. The small cemetery at the corner of the Number Five and Cassidy Road has a marker for Calistia Ermina Signor, daughter of Sidney R. and Mary L. Signor, who died September 5, 1848, age 1 year, 3 months. There is also a marker for Orin Harran who died April 25, 1850. The 1850 U.S. Federal Census Mortality Schedule lists an Orin Hison age 1 year who died April 25 in Bellmont. The 1850 Census for Bellmont lists a George and Clarinda Herrin who had a 3 year old daughter. They might be the parents. There are five other stones in the cemetery that have no names on them. An Abigail Herron, age 66, died in Bellmont on April 6, 1850 according to the Mortality Schedule.

There was an Abigail Herron in Class No. 3 East Bellmont which would be the area near that cemetery. On the 1850 census next to George is Thomas, age 67, so Abigail might have been his wife and Orin's grandmother. This is all speculation. One learns when doing genealogy that the spelling of names is only as accurate as the one recording them.

The unexpected discovery of ledgers like this surely add to our knowledge of our Town's history.

References:

Pages from the Methodist Ledger
Taintor Dawson & Company 1858 map
Wikipedia.com Methodism
U.S. Federal Census

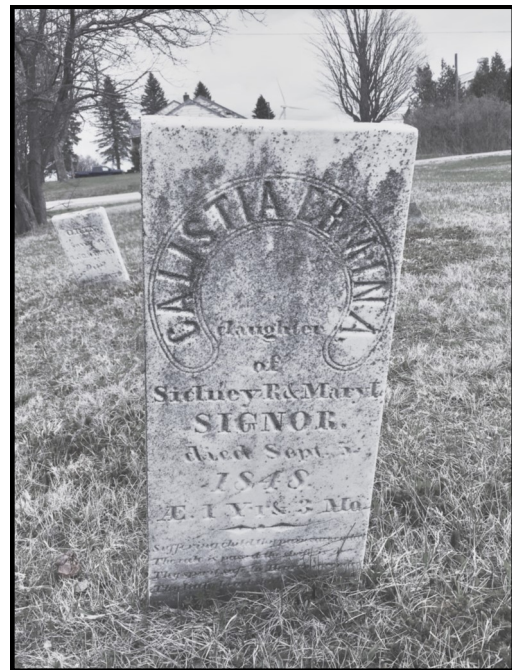

The small cemetery shown on the left is located on the No. 5 Road and is the one referred to in the text. The grave marker for Calistia Signor is on the right and is shown enlarged above.

The dots on the map of the Town of Chateaugay on the next page show the locations of the schools where the groups met.

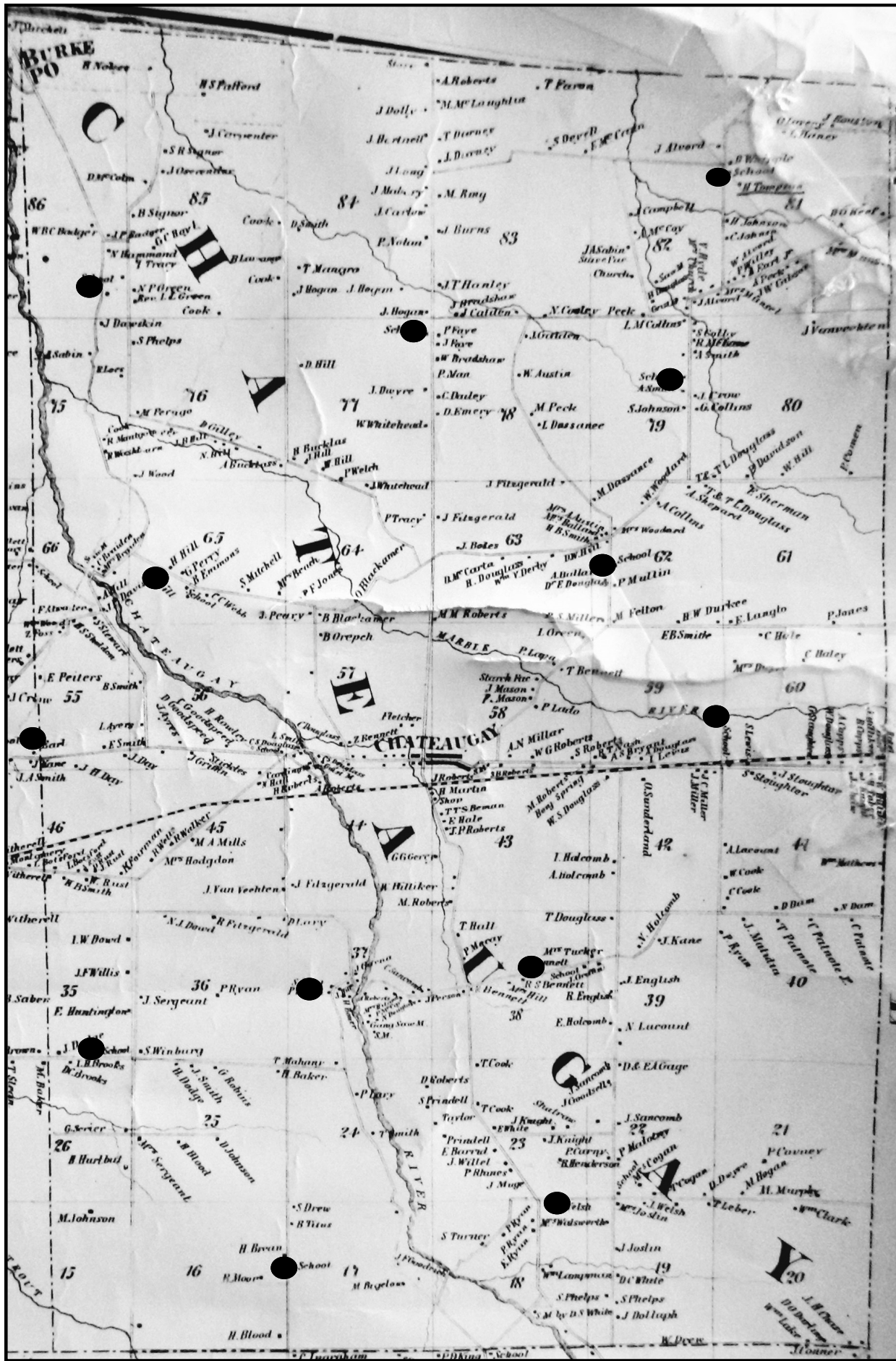

Sample Transcription from the Methodist Ledger

Methodist Circuit Riders Book

1845 – 18__

Information respectfully submitted by Ebenezer Pease, Preacher, Chateaugay June 6, 1846

*The number of some Classes changed. The members changed as people moved.

Class No. 5 Atwater

1845-46-47

Ebenezer Peters
Franklin Atwater
Lucetta Atwater
Dennis Persons
Eunice Persons
Malinda Sheldon
Hiram Sheldon
Benj Blackmore
Mary Blackmore
Jessie Ketcham
Amy Ketcham
Sidney Mitchell
Lucy Mitchell
Laura Percy
Margaret Danskin

Class No. 6 Bromley's South Settlement

John Cane/Kane
Hannah Kain/Kane
Benj Bromley
Lydia Bromley
Sally Whipple
William Bromley
Mariah Bromley
James Willis
Jane Willis
Dudley McGoon
Patience McGoon
Sally M. Bromley
Betsey Hall
Esther Furson
Nathaniel Whipple
Ann E. Whipple

Class No. 8 Signor 1845-46--47

Benj Signor
Thirza Signor
Obadiah Walsworth
Judith Walsworth
Katherine Stores
Sarah Pickering
Betsey Pickering
Benjamin Pratt
Sophia Pratt
Mary L. Signor
Henry Signor
Alonzo A. Clarke
Sally A. Clarke
Emily J. White
Mary Turner
Daniel Signor Aug 27, 1845
Harriet Pickering Jan 21, 1846
Mary Jane Dolloff May 27, 1845
Tilpha Webster
John L. Bigelow & Fanny Bigelow

Class No. 9 Hazen/Cartwright

David Hazen
Rebecca Hazen
Horace Hazen
Emerson Hazen
Mariah Hazen
Emily Hazen
Lucy Willis died Jun 25, 1846 typhus
Hiram Cartrite/Cartwright
Mary S. Cartrite
Emiline Baker
Sally T. Pease died 1846-47 age 41
Lewis Austin
Rufus Hazen
Filinda Squire
Mary Childs
Bersheba Vaughn
Clarissa J. Cartwright

*Note: Meets between 4 corners & stone schoolhouse near Mr. Bullard's

Class No. 10 Kenneson or Cornelia Stafford Dist. 1845-46-47

This class meets in Belmont in the Kennison neighborhood

Cornelia Stafford
Harriet Stafford
Walter T. Stafford
Mary Collins
Alonzo A. Clark
Benj Courier/Curien
Sarah Courier
Jacob Kenneson
Michael Lampman Feb 28, 1845
Sally Lampman "
Louisa Lampman "

Sally Chase Feb 28, 1845
Louisa Chase
John B. Kenneson
Charles Miller
Harriet Kenneson Jan 15, 1845
Peter Kenneson "
Mary Anderson June 10, 1845
James Chase
Betsey Lampman

Henry C. Lavery

Chateaugay Native – Inventor and Marketing Genius

By

Mick Jarvis, Chateaugay Historical Society

This off-beat look at another Chateaugay related story is just one more interesting tale in the history that our hometown keeps revealing as we peel it back layer by layer.

Phrenology

During the 1800s, it was believed that one could learn much about their behavior and personality traits by studying the bumps on their head, a science known as phrenology.

Franz Joseph Gall, a German neuroanatomist and medical researcher, claimed to have “discovered” and developed the field of phrenology around 1800.

He believed that the brain was comprised of different pieces or organs—twenty seven to be exact. These organs supposedly determined behavior and personality. The shape and contours of one’s skull were believed to mirror those brain regions or “organs.”

Over the next fifty years or so, the new science of phrenology would become a mostly main-stream subject. Thanks to the efforts of George Combs, a Scottish lawyer, the field grew. Even a periodic journal was regularly published and a significant medical community following was developed.

By the beginning of the 20th Century, phrenology

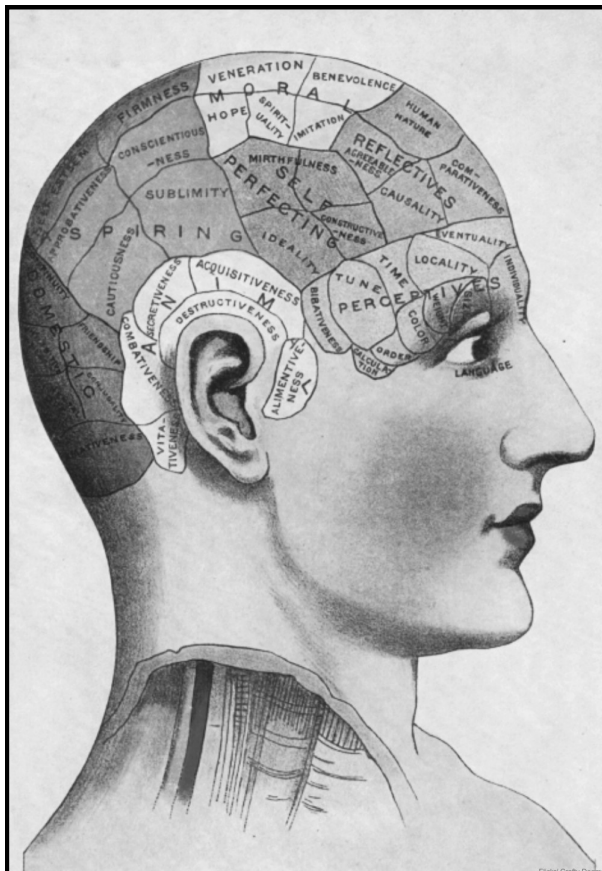

*Phrenology Map of the Brain
(Google Image)*

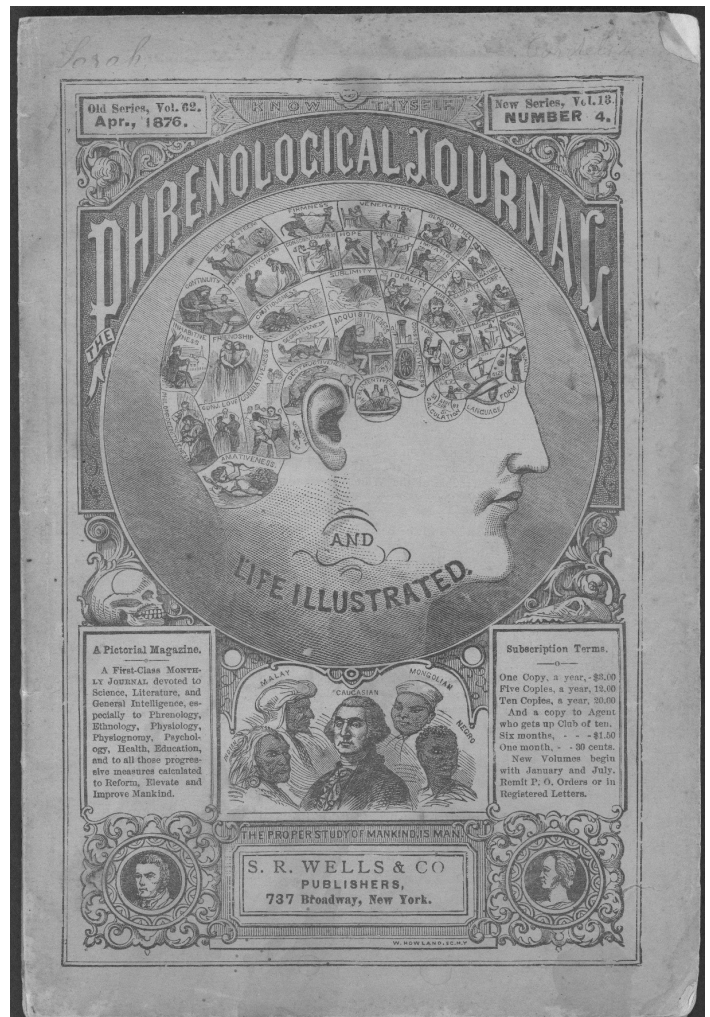

had reached its zenith and “research” to better measure and map people’s skulls was happening regularly. In 1905, enter Chateaugay native, Henry C. Lavery.

Lavery’s Early Years

He was born in 1870 and grew up on the 65 acre family farm on what is now Belle Avenue (the street was not officially established by the village until 1886). He was the eldest son in a family of eight children. Three of his sisters died in childhood. His remaining sisters all completed the Teacher Training Class at the Chateaugay Academy and became teachers in local or area district schools. His brother, Andrew, became a skilled carpenter and worked throughout the local area before relocating to the Superior, Wisconsin area in 1905.

In the late 1890s, Henry journeyed to Superior, Wisconsin and worked in a number of hotels. He eventually became the head main-desk clerk at the upscale Richelieu Hotel. He regularly returned to Chateaugay via rail to visit family and friends. On one of those visits home in May of 1900, he married another Chateaugay native, Margaret McElroy, in St. Patrick’s Church on May 30th. They departed that evening on the train for a wedding trip to New York City and Washington, DC. The couple returned to Henry’s home in Superior, Wisconsin where they would raise their family.

As a youngster, Henry was said to have enjoyed inventing all sorts of gadgets and devices—something he would carry into adulthood. He was later credited with various inventions including: a cash register, a type of railroad gate, a Maritime life preserver, and a check writing machine. Henry continued his innovative bent while living in Wisconsin. This not only stoked his creative fires but brought a measure of financial security to his family.

The Fascination with Phrenology

He developed an interest in the field of phrenology and, in 1905, was granted a patent for the “Anatomical Measurement and Recording Machine” by the U.S. Patent Office. His highly detailed patent application was almost 18 pages long. His device had over 1,900 parts but proved to be unworkable. Not to be deterred, he redesigned and retested several ver-

sions of the machine. The next year, he had a working prototype which was popularly referred to as the “Lavery Phrenologist.” The *Chateaugay Record* carried an account of the 1906 version of the device in an article that appeared in the July 6th issue:

H. C. Lavery, of West Superior, Wis., a son of Mr. and Mrs. Hugh Lavery of Chateaugay, is of an inventive term of mind and has already a number of inventions which have attracted much attention. His latest work is known as the “Lavery Phrenologist” which is claimed to read the mind in one minute, and scientifically measures, delineates, prints and delivers on a sheet of paper the degree of development of every faculty of the mind. It is more scientific and accurate in its readings than any professor of the art, because it gives accurate and positive measurements, while man relies on touch and observation. It also tells whether a person would be successful as a lawyer, minister, doctor, orator, mechanic, musician, financier, teacher, or any of the varied vocations of life. Those who have tried the machine pronounce it a wonderful invention and predict for the young inventor a remarkable career.

Despite the positive and glowing account in his hometown newspaper, his device still faced some obstacles. It was not consistent and reliable with each use so it was retooled, rebuilt and redesigned again and again for the next 20 plus years.

A Working Model

Finally, in 1929, his vision was realized and he had succeeded in designing a functional version that worked as advertised. He took on a partner, Frank P. White, who brought the needed financing into the picture. To provide the necessary funding, White had liquidated his interest in a little-known sandpaper company where he had worked for a number of years, that company would later go on to become the 3M Corporation.

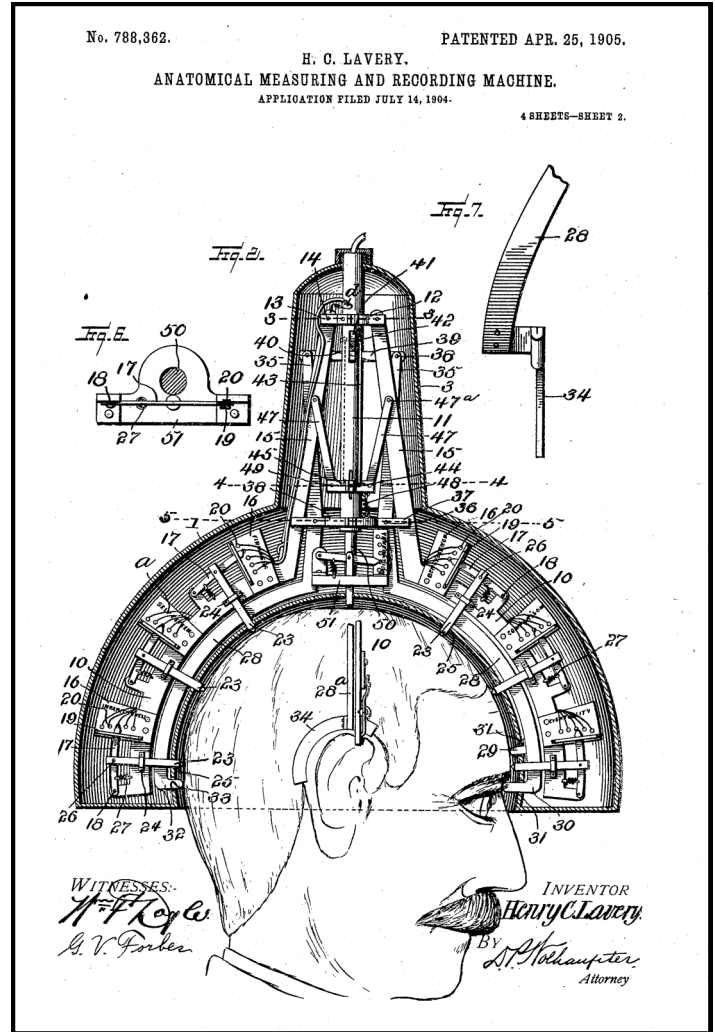
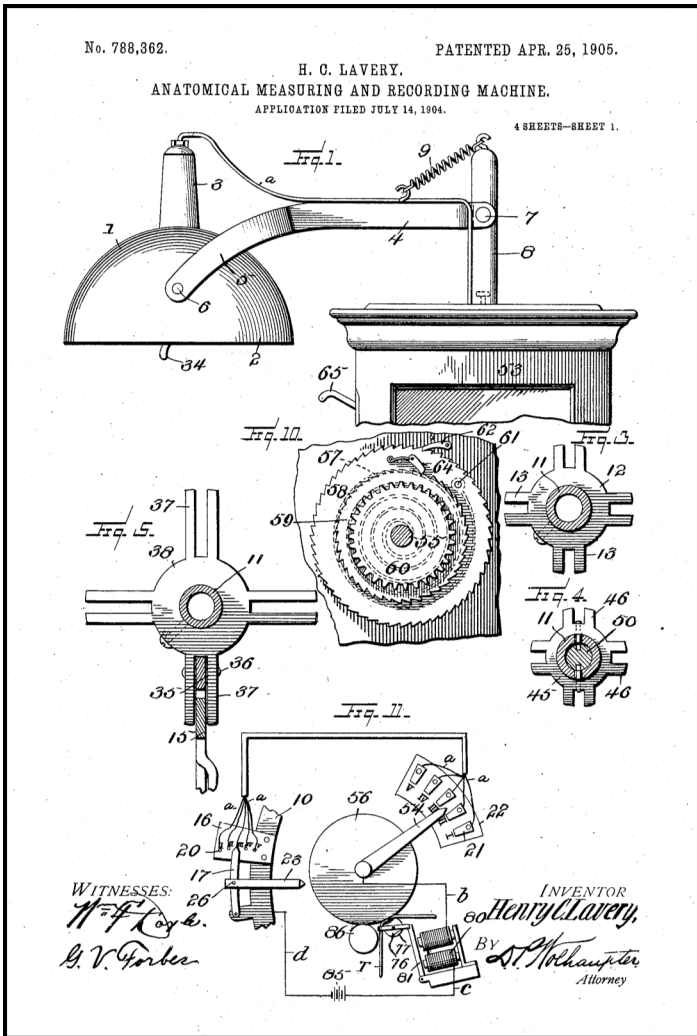

Henry C. Lavery Patent Application Drawings

(U.S. Patent Office Archives)

With the necessary financing available, they formed the “Psychograph Company” and began large-scale manufacturing of the device.

Lavery’s machine was intended to “map and measure the bumps on a person’s skull using 32 metal probes that made contact with the head” and supposedly measured 32 “mental faculties” (five more faculties or organs than was theorized when phrenology was developed). Lavery, who was now referring to himself as a “profound thinker”, had a marketable product which could take advantage of the public’s interest in phrenology.

By using his knowledge of marketing gained from his years of inventing, his product went mainstream, so to speak. At first, his company built 33 machines and leased them to business people around the country. It was common to see them in movie

theaters, hotel lobbies, or in a variety of retail stores. The lease called for \$2000 down [approx. \$29,000 in 2019 dollars] and a monthly rental of \$35 [about \$500 today] each month.

Lavery in the Chateaugay Record

In the May 1, 1931 issue, the *Chateaugay Record* published an article about the success of Lavery’s newest version of his device. The *Record* headline screamed, **Former Chateaugay Man Inventor of Marvelous Machine**. The three column story that accompanied the headline included the photo on the next page which showed Lavery in a product show surrounded by people watching one individual being screened by the Psychograph.



The 1934 World's Fair

In 1934, Chicago hosted a World's Fair called "A Century of Progress Exposition" which ran from May until November. Lavery and White set up a Psychograph device in a space at the expo and did a steady business throughout. They had crowds waiting in line each day to be measured by the machine. The partners reported that they had taken in \$200,000 [approx. \$3.7M in today's dollars] over the course of the Chicago event.

During their heydays, the field of phrenology and the Psychograph were both popular and very profitable. Both the science and the device were even incorporated into some vocational programs and used to provide information for career counseling.

The phrenology era began a significant decline shortly after the Chicago World's Fair. By 1935, the number of diehard adherents was falling rapidly and Psychograph usage and device sales declined. Orders were cancelled, leased machines were returned, and the Psychograph Company quickly lost money

Phrenology Falls From Favor

New scientific research in the late 1930s and 1940s found much to dispute and disprove about phrenology, causing the whole industry around it to collapse. Today, the whole phrenology/Psychograph field has been discredited and is now considered pseudo-science. It does, however, still have a very minor presence in the popular consciousness with an entire exhibit devoted to its once lofty reputation in the Museum of Quackery in St. Paul, Minnesota.

Although Henry C. Lavery's hallmark invention has been relegated to the dust bin of history, it was wildly popular in its day, and was hugely lucrative in its time. However, we know little of Lavery's post-psychograph life.

In any event, he certainly made his mark in the now irrelevant field of phrenology during its halcyon days of high public favor and equally high profits.

In the end, Henry C. Lavery was yet another Chateaugay citizen who made a mark, however large or small, in our nation's social history.

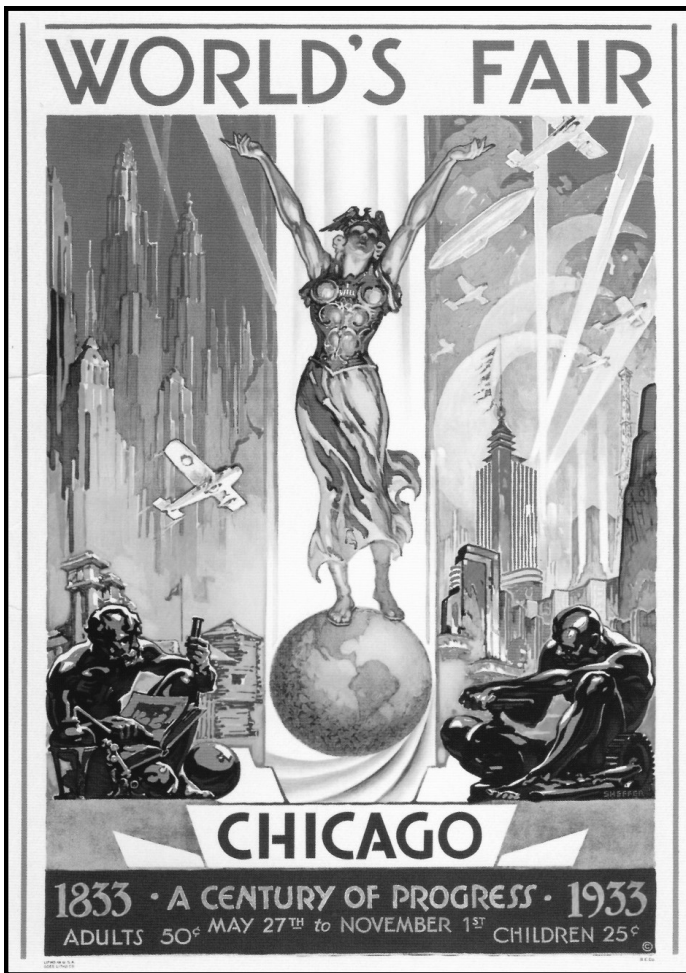

(Google Image)



Henry C. Lavery adjusts a Psychograph to do a reading on a client.

(Google Image)

Sources:

[Chateaugay Record – 5/1/1931, 6/1/1900, 7/6/1906](#)
[Chateaugay Journal – 5/30/1900](#)
<http://www.museumofquackery.com/devices/psychograf.htm>
<https://www.vintag.es/2017/09/bad-invention-psychograph-phrenology.html>
<http://washuu.net/Med-Lec/psychograf.htm>
https://hatch.kookscience.com/wiki/Lavery_Electric_Phrenometer
<http://www.museumofquackery.com/devices/psychist.htm>
<https://patents.google.com/patent/US788362>
<http://www.wikipedia.com>
<https://dustyoldthing.com/phrenology-craze/>
<https://www.ripleys.com/weird-news/psychograph-phrenology/>
https://www.huffpost.com/entry/maybe-this-would-stimulat_b_162937
<http://www.ancestry.com>

Do you enjoy genealogy and history, particularly local history? The Chateaugay Historical Society is a great venue for your interests. We are always looking for folks who would like to get involved.

We currently have two openings on our Board of Trustees.

We are also constantly in need volunteers. We always have many projects in the works: researching, developing exhibits, our quarterly newsletter, organizing, filing, help cataloging our archives, and many others.

We welcome any level of involvement; an hour of volunteer time here or there, helping with one of our long-term projects, researching, writing, or, perhaps, even serving on our Board of Trustees. Any contributions of time and effort would be most welcome.

Chateaugay has many stories to tell and much history to be archived and preserved. If you have an interest, we'd be glad to have you join us.

The Shoemakers of Chateaugay

By

Mary H. Humiston, Chateaugay Historical Society

During the 1850s and into the early 1900s, Chateaugay was a thriving community with a number of industries and manufacturers. One industry not often mentioned (or maybe taken for granted) was the manufacture of boots and shoes. Beginning in the 1850s, a local shoe industry was growing in the village, maybe supported by the presence of the local tannery created by W. V. Derby and then expanded by H. A. Douglas. A local source of readily tanned hides would be an incentive to put the leather to local use.

In larger cities, the boot and shoe industry occurred in large factories. Lynne, Massachusetts was noted for its shoe production and advancements. The shift from making shoes completely by hand to the use of machines began at about 1845 with the first Rolling machine for pounding the sole leather to compact the fibers. Until then, the individual shoemaker used a lapstone and hammer. In 1846, Elias Howe invented the sewing machine which made it possible for the shoes to be stitched together quickly. Another invention sewed the sole leathers into layers which was much faster than hand sewing.



Cobbler's Lap Stone

(Google Image)

In the smaller towns and villages, shoes and boots were still being created by one person, the shoemaker, in his home or at a nearby shop. As the tools and techniques changed, many individuals joined with or were hired by a larger manufacturer who provided the space, equipment and materials to produce the boots and shoes. This appeared to be happening in the Chateaugay community. Three individuals, William S. Peake, Antoine Pepin and Levi Patterson, seemed to lead the local industry. Patrick Cooney was another early contributor.

The first U.S. Census to record occupations and give us a hint in regard to this local industry, was the 1850 Federal Census. The census for the Town of Chateaugay that year recorded eight individuals who listed their occupation as shoemaker. By 1860, there were sixteen listed in the shoemaking business, either as a “boot and shoe manufacturer” or shoemaker. Many were apprentices, some young in age, and Canada was often listed as their place of birth. A few were from the New England states. That many shoemakers seemed large for one small village. Using the *Federal Non-population Schedules* recorded at the time of the censuses along with business directories for the 1850s and 1860s, plus newspaper advertisements and articles, I found individuals were listed as either a “manufacturer of boots and shoes” or a “shoemaker.”

In 1850, the following individuals listed their occupation as shoemaker: Hiram Totman, Jedidiah Smith, Mr. Cunningham, Lewis Patterson, Richard Scott, Peter Carbin, Joseph Placy (sp?), and Peter Shouss (sp?). The *1850 U.S. Census Non-Population Schedule for Industry* stated that Levi Patterson had a ‘Shoe and Boot’ business that included a capital investment value of \$250, 3 employees and produced 400 pairs of boots and shoes at a value of \$800.

At the time of the 1860 census, the industry schedule listed Patrick Cooney as owning a:

‘Boot and Shoe factory’ that employed 4 males; produced 1000 pairs of boots at a value of 3,000 dollars and

1000 pairs of bootees and shoes at 1000 dollars value. His raw materials included 550 sides - upper leather, 4,000 pounds sole leather, 50 lbs thread, 10 cord wood and 20 gallons fluid [oil for the leather treatment].

William Derby, tannery owner, also owned a boot and shoe factory as did Antoine Pepin. The others listed on the Census were shoemaker apprentices or just shoemakers. Maybe they were employed by Cooney, Derby or Pepin. The following individuals were listed in the actual 1860 Census as shoemakers – Simon Umphies, Jedediah Smith, Eugene Quaria, Wm. Peake, Archibald Quillan, Vitale Marseau, H. Pepin, Bleanier LaVasar, Francis LaRoux, Louis LaDue, Antoine Jarvis, Joseph St. Antoine, John Henderson, Albert Deschambeaut, T. B. Corbin, Joseph Blount, and Paul Taron.



A Local Leather Supplier

(Chateaugay Record - April 29, 1881)

The 1880 and 1900 Censuses indicated the beginning of a decline in the shoe business and by 1900 only five individuals were listed – Levi B. and John Peake (sons of William Peake), Antoine Pepin, John Sturgeon and Joseph Klock. The number continued to decrease until 1920 when no shoemaker was listed in Chateaugay.

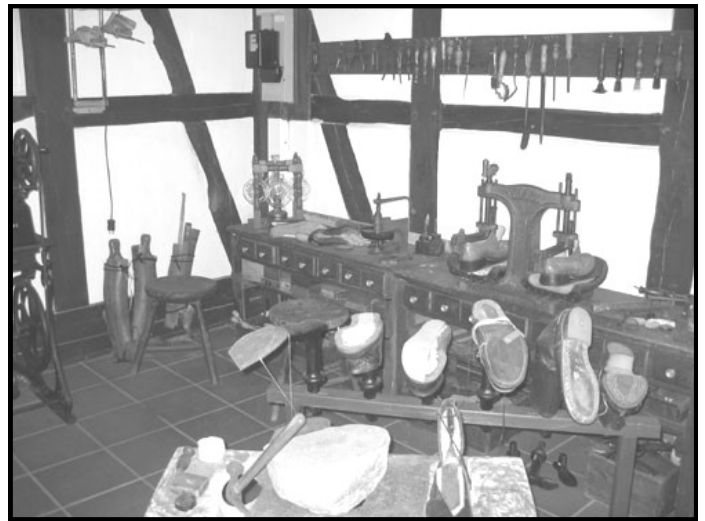

A Shoe Repair Shop

(Google Image)

The 'Boot and Shoe' Makers

Patrick Cooney

Patrick Cooney first began his career in Malone working as a shoemaker with Thomas Lanton, manufacturer of boots and shoes. Patrick moved to Chateaugay and opened a business of his own. By 1860, he had moved to the Town of Clinton, opening a cobbler shop. A cobbler repaired shoes whereas a shoemaker made a new shoe. He then went into farming and shoe repair and, finally, just farming.

William V. Derby

Although involved in the tannery business in Tannery Hollow, William Derby did have a boot and shoe manufacturing business connected to his tannery in 1860. Production included 2,000 pairs of boots and 5,000 pairs of shoes.

William S. Peake

According to news articles, William Peake conducted an extensive boot and shoe business in Chateaugay employing many laborers. Born in 1826 in Hinchinbrook, Quebec, Canada, he moved to Chateaugay between 1855 and 1857. He listed his occupation as shoemaker in the 1860 Census, but soon moved to the level of manufacturer. The *1862 Directory of Franklin County* listed Peake & Ryan - Boots and Shoes (William Peake & John Ryan) and in the

1871 Directory, listed Peake, W. S. - Boot and Shoe Manufacturer and dealer. On the special Industrial Census for 1870, Peake listed 5 employees and production as 500 pairs of boots and 200 pairs of shoes. His total dollar value for the year was \$3,000 in boots, \$750 in shoes and \$1000 in repairs. The 1880 Census listed William as Boot and Shoe Maker, son Benjamin L., shoemaker and son John Peake as working in the shoe shop. The business appeared to be declining in value and size.

William S. Peake died November 11, 1896 at the age of 71. After his death, his two sons continued the business. John S. Peake established a shoe store in the Howard Block about 1894 – this would have been after the Main Street fire in 1893. He confined his business to men and

boys shoes. His merchandise came from wholesale houses, especially Emerson Shoe Co. and the M. A. Packard Shoe Company. The 1897 and 1898 *Chateaugay Directory* lists Benjamin L. Peake, shoemaker, River Street, residence 28 Church Street and John S. Peake, Boots and Shoes, East Main St., residence 28 Church Street. It appeared that the local manufactured shoes were being replaced by wholesale manufacturers from afar. In 1909, the *Chateaugay Record* reported that John S. Peake was fixing up his brother Benjamin's shoemaker shop located next to the bank on River Street to be used as a shoe store and repair shop. Benjamin died in 1919. In 1920, E. A. McCoy purchased the property in order to expand his growing business which was adjoining Peake's. John Peake died in 1925.

EMERSON Model
TAN SHOE For 1897

The Cadet Toe is the Spring Style. They are "originals" — not copies.

They lead in every improved structural feature—every item of comfort, convenience and fashion.

They have **Pratt Fasteners** [no knots, no bother].

Fast Color Eyelets and Hooks [never get brassy.]

They are **Anti-Squeak** [patent fillings between soles].

They are **Up to Date.**

The stock of which they are made is the best this world produces.

They are designed by artists in footwear and made by the most Skilled and Best Paid Shoemakers.

J. S. PEAKE,
 Howard Block, Main St.

Chateaugay Record

April 29, 1897

Antoine Pepin

Antoine Pepin was a well known boot and shoemaker in Chateaugay. He was born in Canada in 1834. His father, Hyppolite Pepin, had been a shoemaker in St. Martine, Chateaugay, Quebec and moved to Chateaugay, New York in 1854, where he continued his trade. Antoine was about 19 years of age when the family immigrated to the United States. He married Mary Sancomb, daughter of Charles Sancomb, in 1855 and they raised a family of fifteen. One can assume that Antoine learned the shoemaking trade from his father. He built or purchased a home at 18 Church Street. In the 1897-1898 *Chateaugay Directory*, his business was listed as shoemaker at 15 Depot. He also ran a shoemaking shop in the front of his Church Street home where he conducted his boot and shoe business until his death in 1908.



*Mary and Antoine Pepin
 Shortly After Their Marriage*

(Photo Courtesy of Arthur and Rebecca Tracy)

The 1860 Industry Schedule described Antoine's business as:

Boot and Shoe Factory, with capital investment of 250; raw materials -150 sides upper leather, 108 lbs sole leather, 12 lbs of thread, 6 lbs of wax, 10 cords wood, 9 gal. oil; type of motive power was hand; 2 employees; average monthly cost of labor \$42; annual production 575 pairs of boots with value of \$1,125 and 112 pairs of shoes & boots value \$150 plus custom work value \$100.

Hyppolyte, his father, was also on the 1860 Census as a shoemaker living in Chateaugay with his wife Marie (Crompt). Antoine continued in the shoemaking business until his death on February 9, 1908 at the age of 73.

Carlisle D. Silver

Carlisle was listed in the *Chateaugay Township Business Directory 1862* as a boot and shoemaker. He married Henriette Derby, daughter of William V. Derby.

Gabriel "Jim" Lopardo

Jim Lopardo, born in Italy, immigrated to the United States in 1912, settling with his father and mother in Hoosick Falls. Jim's father was a shoemaker and owned his shop. Gabriel "Jim" moved to Lyon Mountain, NY where he continued in shoemaking and then, moved to Chateaugay around 1934. He continued in the shoe business until 1951 when he sold to Earl Begore. The shoe shop was on the north side of East Main Street in the Masonic Block. Jim Lopardo then went into the barbering business, taking over Luke's Tonsorial Parlors from Luke Sampica.

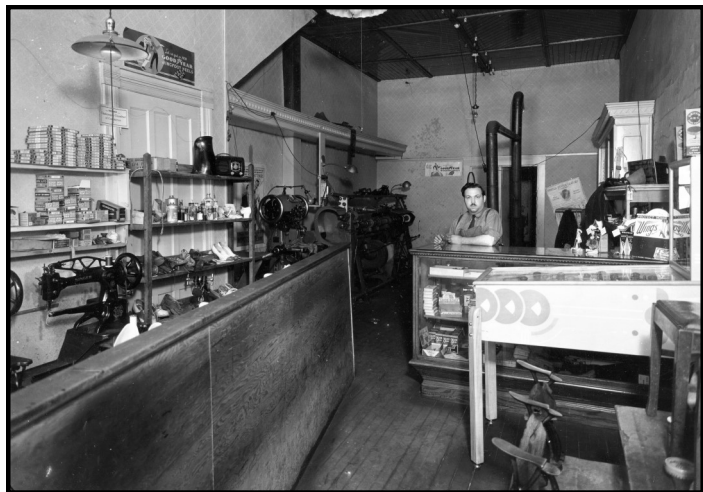

Jim Lopardo in his Shoe Repair Shop in the Masonic Block

Earl Begore

In 1951, Earl Begore had purchased the Lopardo business. Then, in 1954, he regretfully closed the shop on East Main St. due to ill health. This was the end of the shoemaking trade in the community of Chateaugay.

For over a hundred years, the shoe industry had been a part of the community – going from a cottage industry to a manufacturing endeavor and then, to a sole repair service.

NOTICE

**I HAVE TAKEN OVER
THE
JIM LOPARDO
SHOE REPAIR SHOP**

**AND
AM PREPARED TO
DO ALL KINDS OF
SHOE REPAIRING**

Your Patronage Will Be Appreciated

EARL BEGORE

Open Daily Until 6:00 P.M.
Saturdays Until 9:00 P.M.

Chateaugay Record

April 6, 1951

A Related Industry

From 1943 to 1949, Chateaugay was the home of Cossack Booties, a slipper manufacturer located on Belle Avenue. See Mick Jarvis's article in our quarterly newsletter; Vol. IX Issue #1 2015 for the full story.

**First Class Shoe Repairing
and Shining Parlor**

Men's Sole Sewed and Rubber Heels, \$1.25
Ladies' " " " " " \$1.00
Ladies' Leather Lifts, 25c
Men's Rubber Heels, 40c

And repair work in general at prices as low and
as reasonable as any place in this vicinity.

Repairing **Children's School Shoes** A Specialty

MASONIC BUILDING, NEXT TO GINN'S
CLOTHING STORE.

G. LOPARDO, Prop.

Chateaugay
Record
August 31, 1934

Sources:

Newspapers

Chateaugay Record and Franklin County Democrat. August 3, 1888; January 12, 1893; November 13, 1896; April 29, 1897; December 20, 1900; May 24, 1907; August 13, 1909; June 17, 1910; Feb 2, 1912; January 24, 1919; June 11, 1920; January 20, 1925; April 6, 1951; August 31, 1934; May 21, 1970.

Business Directories

Franklin and Clinton County Directory 1862 – 1863.

Northern N.Y. Business Directory Chateaugay 1871

Chateaugay Business Directory – 1897 – 1898

Maps

Franklin County Historic Land Ownership and References Atlas 1876

Sanborn Fire Maps 1884, 1892

US Federal Census

U.S. Selected Federal Census Non-Population Schedules, 1850 – 1880.

U.S. Census Records – 1850, 1860, 1870, 1890, 1900, 1920, 1930, 1940.

Websites

Shoes of the 19th Century <https://people.seas.harvard.edu/~jones/mckay/history.html>

Upper Canada Village – Shoemaker. <http://www.uppercanadavillage.com/things-to-do/tour-the-village/shoemaker/>

Shoe Repair / Shoemaker's Tools



The tools shown in the top row and bottom left were owned and used by Jim Lopardo. The stand and shoe sole forms shown at the lower right were used by Antione Pepin

Artifacts/Objects from Chateaugay's Early History

By

Mick Jarvis – Chateaugay Historical Society

We are so very fortunate to have such a deep and interesting history for our little town. Being the mother town for Franklin County has given Chateaugay somewhat more of a prominent historical profile. In addition, having a local newspaper which was regularly published for over 120 years has left us with a treasure trove of information. During that entire time, the vast majority of all those published issues have survived, either on newsprint or in a digital form. The *Chateaugay Record* and the *Chateaugay Journal* were joined by so many other area newspapers whose editions also still exist and add to that history.

That said, the other part of our local history comes from the artifacts and objects that have survived over the years. Since the Historical Society's chartering in 2006, the outstanding support shown to our group has allowed our archives to grow to a volume and significance we never dreamt of thirteen years ago. Our collection of photographs, objects and documents seems to expand weekly.

There are objects out there that are especially significant. These important artifacts have survived the years and have surfaced to give us a sense of the extent of our small town's past and the footprints it has left in history. Luckily, some of these important pieces are in our collection here in Chateaugay. Some are in other collections or locations, but are documented and known to exist. Here are some of the most significant.

Gates Hoit's Hand-Drawn Map of the World

Gates Hoit was a very prominent early community leader. He was sought out by early governors for advice, served in various local elective offices, and was a member of the NYS Assembly from 1810 to 1812. Well-read and always curious, he sat and drew a map of the world which he dated: May 20, 1800. The map is now in the collection of the Chateaugay Historical Society, having been donated by the estate of Herbert McCoy Jr. Gates Hoit was the great, great, great grandfather of Mr. McCoy.

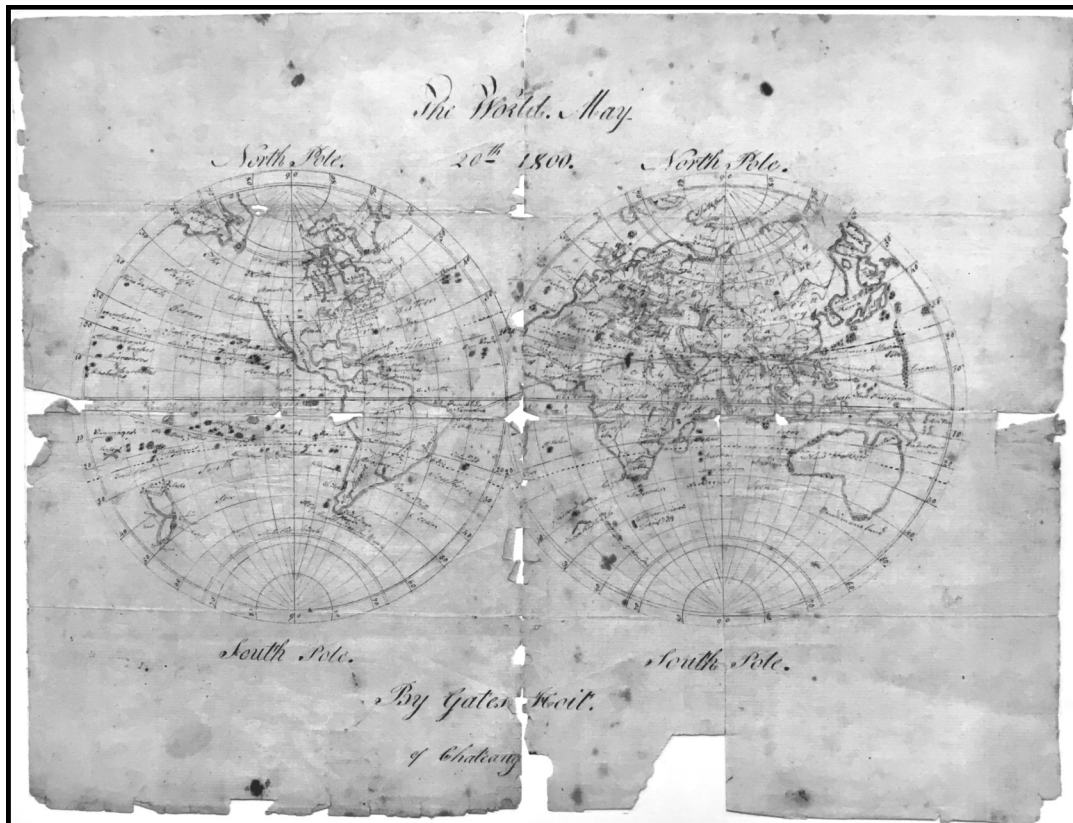

Oil Portrait of Admiral Theodorus Bailey

Admiral Bailey was born in 1805 in the small home that now sits behind Wendy's Quick Stop (formerly Bova's Grocery) on Depot Street. He joined the Navy at age 12 and had sailed around the world three times before he turned 18. He eventually rose to the rank of Admiral and was the hero of the Battle of New Orleans towards the end of the Civil War.

Chateaugay was the home of a Grand Army of the Republic post beginning in 1885. It was made up of Civil War veterans and was named for Benjamin F. Roberts, one of Chateaugay's founders. In 1890, the GAR post was renamed the Admiral T. Bailey Post. At the time of the name change, the post was presented with a framed oil portrait of the Admiral. That original portrait was destroyed in the East Main Street block fire of 1893. The Post commander, working with the Admiral's children, replaced the portrait with another from the same artist.

Today, that replacement portrait hangs in the American Legion John E. Harrica Post #875 on West Main Street. It was recently repaired and restored by Phillips Art Conservation of Essex, NY through the joint efforts of the American Legion, the Chateaugay Rotary Club and the Chateaugay Historical Society.

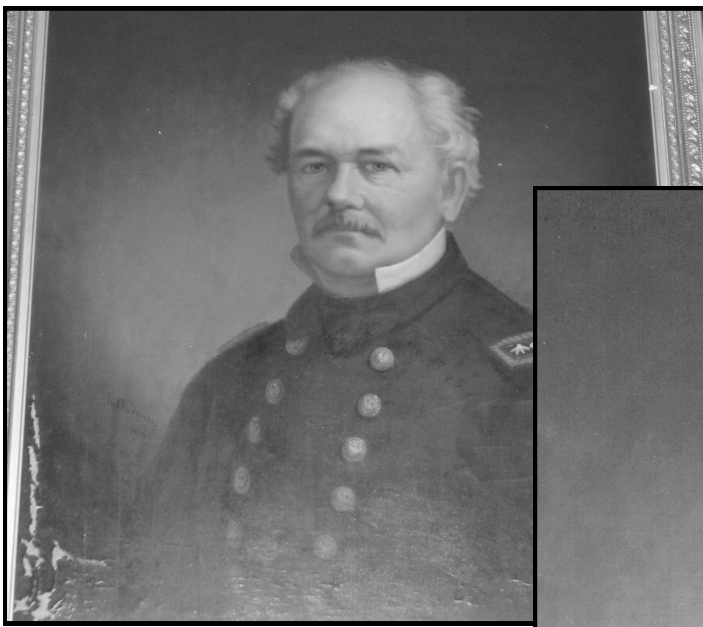

The upper photograph shows the portrait prior to its repair and restoration. Note the lifting paint sections at the corner of the work. The surface of the painting had become dirty and dull over the years.

The larger image shows the fully cleaned and restored painting. Note the repair of the lifting paint in the corner and the overall brightness of the work. Now, even the artist's signature just below the Admiral's right shoulder is visible.

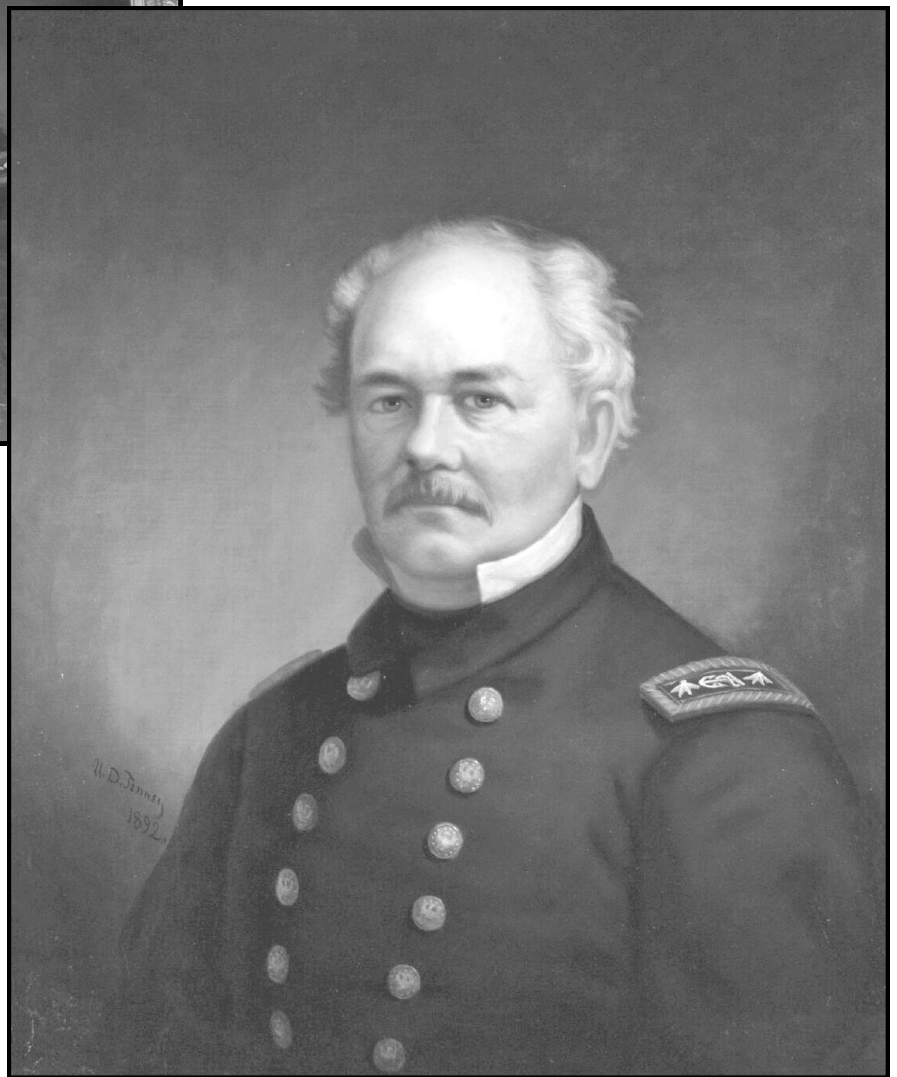

War of 1812 Military Drum

This bass drum measures 24 inches across and is 18 inches tall. It has been repaired and fully restored. The Historical Society learned of it when we were contacted by the webmaster of a website dealing in militaria. The drum is associated with the Col. Thomas Smith family and had a written note attached to it. It had been sold to a private collector. While it is **not** in local hands, we do know that it exists and is in an environment where it is being properly and safely maintained—another piece of Chateaugay’s past.

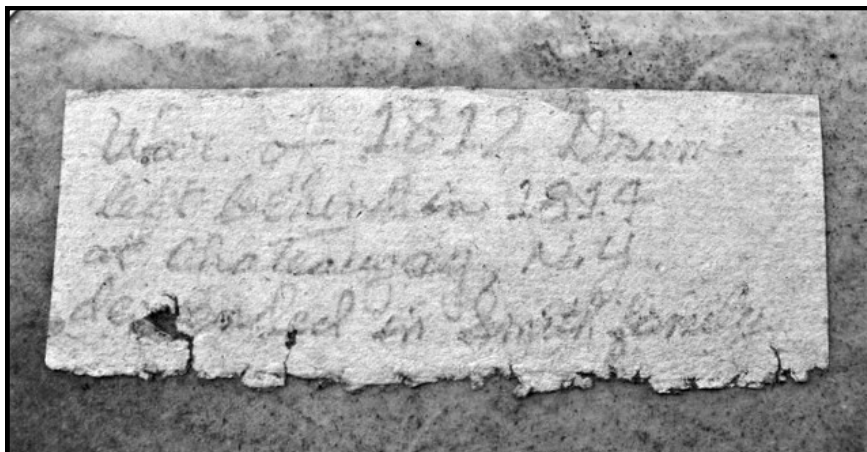

The drum note reads:

*War of 1812 Drum
Left behind in 1814
At Chateaugay, N.Y.
Descended in Smith family*

14 Star Flag – Nathan Beman

This 14 star, 10 stripe piece is called a parade and rally flag. It is one of only three known United States flags displaying 14 stars. This represents Vermont's admission as the 14th state in 1791. The flag measures 20¼" by 30¼". The stripes are silk ribbon and are hand sewn together. The blue field for the stars is 10¾" square. The stars are 1¼" in diameter. The flag was found in the Beman home in Chateaugay. This house had been the home of Frank Beman (great-great-grandson of one of Ethan Allen's "Green Mountain Boys," Nathan Beman, b.1757, d. 1846).

The flag is thought to have been presented to Nathan Beman as a gift sometime between 1795 and 1815.

It was sold to a collector by a specialty auction house in Maine in 2005. It reportedly brought more than \$24,000 at that auction.

Again, this particular object is **not** in local hands, but is known to exist as a Chateaugay-related piece.

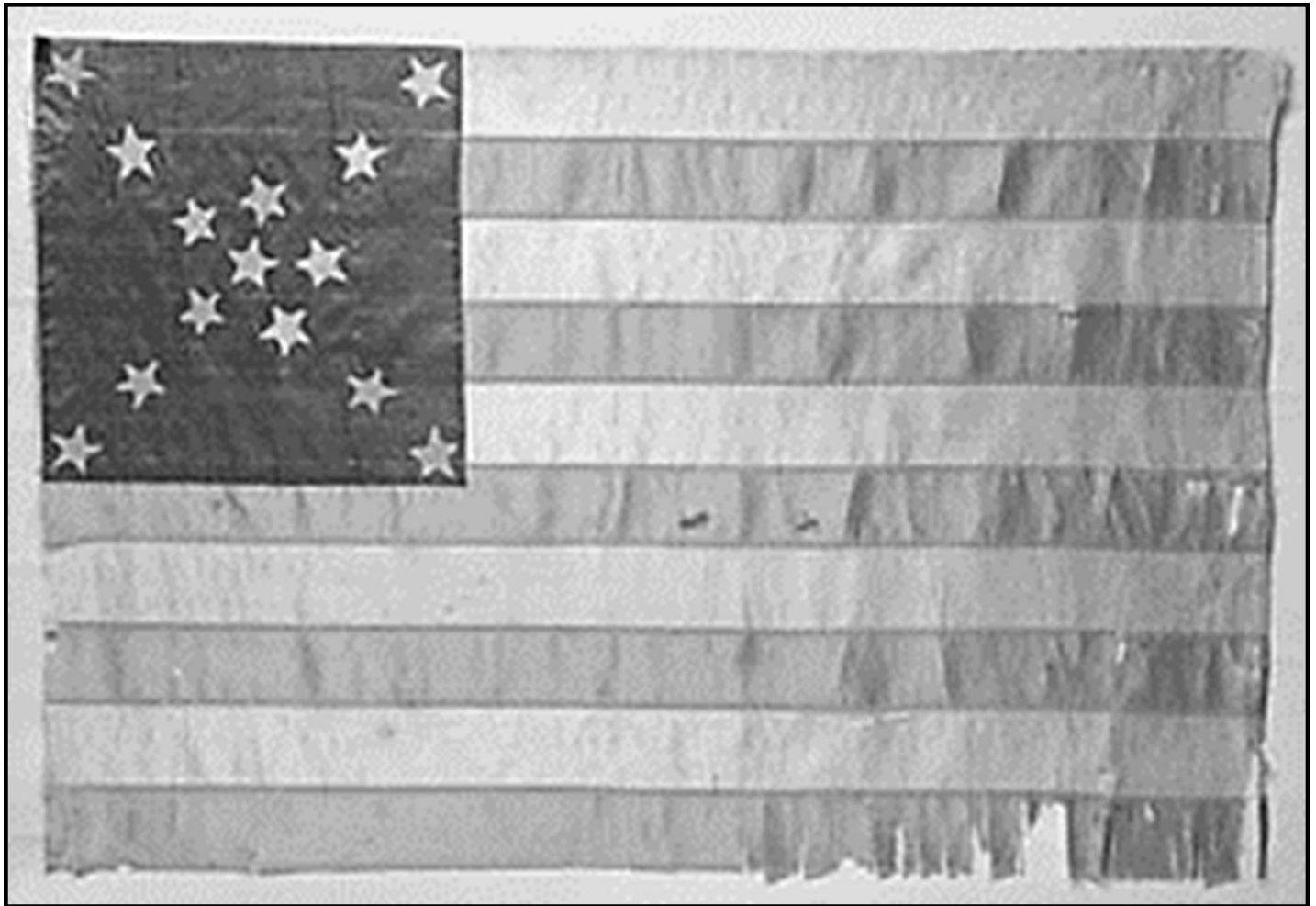

PLEASE NOTE: *Articles and photos are property of the CHATEAUGAY HISTORICAL SOCIETY and/or authors unless otherwise noted. They may not be used without permission.*

Colonel Thomas Smith's Masonic Apron

This piece dates back to the post-War of 1812 era. It was presented to the local Masonic Lodge in 1940 by H.B. Smith, the great grandson of Col. Thomas Smith. There was a notation accompanying the apron that had been written by his aunt, Mrs. Daniel S. Coonley that stated that the apron was worn by Colonel Smith in 1822.

As reported by the *Chateaugay Record* on June 10, 1941:

According to Grand Lodge, this type of apron, white lambskin edged with red silk including the flap with an inverted delta of red silk in the center of the apron, was worn by Knights Templar. They began wearing these aprons about 1820. The aprons were part of their regalia until Civil War time. The red silk has become somewhat faded through the years and is now almost brown. Whether the Colonel was a member of the Commandery is not known. A Commandery at Plattsburgh was organized about 1826 or 1827 and the Commandery in Malone was organized about 1884 or 1885.

Colonel Smith owned a building called Colonel Smith's Tavern, located on the present site of the former Masonic block or Beman block. It was in this tavern that Rainbow Lodge held its meetings. In 1814 during the War of 1812, when the British occupied Chateaugay, the British soldiers ransacked the Lodge rooms and took the jewels, carpet and regalia of the Lodge. It is a coincidence that the first Lodge should have met in a building on the same site as the building in which the present Lodge meets [This building was the Beman/Masonic block that was demolished during the summer of 2019]. Smith's Tavern later became known as the Franklin House. It burned in 1857.

The apron is currently in the possession of the local Frontier Lodge No. 517, F. & A. M.



The Gates Hoit Papers

Thanks to the generosity and commitment of the estate of Herbert McCoy Jr., the Chateaugay Historical Society is now in the possession of the early papers of Gates Hoit. This collection includes early Justice Records for the town that date to 1818, Hoit's business ledgers dating from 1809, various letters, and notes written by him while carrying out his duties as Town Supervisor, Town Clerk, and land agent for the various speculators who held vast tracts of undeveloped land in the town.

Perhaps most significant in this collection is the hand written account of his pursuit of the British soldiers who came through town during the War of 1812 and ransacked Colonel Thomas Smith's tavern at the Four Corners. They had made off with the Masonic regalia including the Lodge's Jewels. He chased them into Canada in an attempt to retrieve the stolen items. Hoit also recounts his interactions with various individuals as he followed the British.



We have many more objects in our archives and we know that there are surely other Chateaugay artifacts out there waiting still to be rediscovered. There may be documents, photos, and objects that will turn up when we least expect them and provide us with more glimpses into Chateaugay's past. In the meantime, we will keep looking. After all, the hunt is as much fun as the discovery.

Beman/Masonic Park Update

The corner lot that held the Beman Block for 126 years is being transformed into a downtown park. The site has been filled and rough graded. Electricity is now available on the site to power the eventual park lighting and the newly installed four-sided clock. The west side of the block that houses the St. Patrick's Church thrift shop is being prepared and clad with metal siding to protect the masonry and give the wall a finished look.

In the spring, tables with benches, the park lighting and a display containing information about the history of the property along with the name stone from the building will be built. The final step will be the spreading of topsoil and the seeding of the grassy areas. Here are two photos of the property as the work progresses in mid-November 2019...



Have You Renewed Your Membership For Next Year??

Check your mailing address label! If it says "Expires 12/2019" on the line immediately below your name on the address label, your membership has now expired. This will be your last issue unless you renew for 2020. We hope you choose to renew. Simply use the separate Renewal Form enclosed with this issue and mail in your check. If you have already renewed, thank you for your continued support!